CUTUB 1: U DIYAARSANAANTA MUSIIBADA

Cutubkaan waxaad wax uga baran doontaa:

- **Musiibooyinka iyo Musiibo ka Shaqeyayaasha:** Waa maxay musiibo, yaase ay ka kooban yihiin xoogagga ka jawaaba.
- **Saamaynta Kaabayaasha:** Waxa ay keeni karaan gurmadyada ba'ani, iyo musiibooyinka gaadiidka, adeegga korantada, telefoonnada, shidaalka, cuntada, biyaha, iyo hoyga, iyo adeegyada gurmadyada
- **Khataraha Dhismeyasha iyo kuwa Dululaatiga:** Xaaladaha kuwa khatarta leh noqon kara ee dhismeyasha iyo wixii ku jira ee waqtiga ay musiibo dhacdo.
- **Khatar Yarayn:** Maxaa la samaynayaa si loo yareeyo khatarta dhaawac ee ku iman karta deegaankaaga.
- **Diyaarsanaanta Hoyga iyo Goobta Shaqada:** Sida aad uga sii diyaargarooobi kartid yaraynta khataraha dhismeed iyo kuwa dululaati oo aadna uga bedbaadi kartid waqtiga billowga ah ee musiibo ka dambeeya.
- **Diyaarsanaanta Mujtamaca:** Sidee bay bulsho waqti hore isugu diyaarin kartaa in ay wax ka qabato musiibo aan dhicin.
- **Dhawrnaanta Shaqaalaha Musiibada:** Shuruucda shaqaalaha musiibada ka dhawra qaansheegasho.

CUTUBKA 1: U DIYAARSANAANTA MUSIIBADA

HIMILOOYINKA	<p>Dhamaadka cutubkan, ka qaybqaatayaashu waa inay karaan in ay:</p> <ul style="list-style-type: none">▪ Sharaxi karaan noocyada khatareed ee ay u badan tahay in ay saameeyaan hoygooda iyo mujtamacooda.▪ Sharxi karaan hawlaha CERT yada iyo doorarkooda waxqabashada degdegga ah.▪ Gartaan tallaabooyinka loogu diyaa garoobo gurmadyada.
WAJAHADDA	<p>Wajahadda cutubkani waxay ka koobnaan doontaa:</p> <ul style="list-style-type: none">▪ Soo dhaweyn iyo Arar.▪ Musiiibooyinkii iyo gurmadyadii dhawaan dhacay.▪ Milicsiga koorsada.▪ Musiibada iyo ka Shaqeeyayaasha Musiibada.▪ Tilmaamaha Ka-qaybgalayaasha.▪ Saamaynta Kaabayaasha.▪ Khataraha Dhismayaasha iyo kuwa kale.▪ Yaraynta Halista Musiibo.▪ Gebaggabada Cutubka.
WAQTIGA LAGU QIYAASAY IN LAGU DHAMEEYO	<p>2 saacadood 30 daqiiqo</p>
DARIIQADA TABABBARKA	<p>Tababaraha hoggaanka ah ayaa ku billaabi doona soo-dhaweynta ka qaybgalayaasha koorsadan isagoo is baraya ama is baraysa dadka baraysana tababara (yaasha) kale, ogeysiinnada maamul ee muhimka ahna bixinaysa. Baruhu wuxuu markaa ka dib si kooban u muraajicaynayaa musiibo weyn oo markaa mar u dhaw aagga ama Gobolka ka dhacday, isagoo muhiimadda siinaya wixii dhacay gadaalkii, casharradii ama khibradihii laga qaatay (oy ku jirto muhiimadda diyarsananta) iyo doorkii ay CERTyadu ku lahaan kareen musiibadaas.</p> <p>Dabadeed, baraha ayaa si kooban u sharxaya himilooyinka koorsada oo kana hadlaya mawduucyada koorsadan lagu qaadan doono.</p> <p>Baruhu wuxuu dabadeed dulmar kooban ka bixinayaa dabecada musiibada iyo gurmadyada aadka u ba'an, isagoo adkaynaya sida ay CERTyadu wax uga geli karaan jawaabcelinta iyo soo kabashada</p> <p>Dabadeed baruhu wuxuu billaabayaa hawl isbarasho ah. Ujeeddada hawshani waxaa weeye in ka qaybgalayaasha lays baro oo lana muujiyo noocyada xirfad iyo awoodeed ee ay CERTyadu u baahan yihiin.</p>

KOOXDA KAJAWAABIDDA XAALADDA DEGDEGGA AH EE BULSHADA

CUTUBKA 1: U DIYAARSANAANTA MUSIIBADA

DARIIQOYINKA TABABBARKA (WAA SOCOTAA)

Inta hawshan lagu jiro, ka qaybgale kasta dadkuu isbarayaa wuxuuna sharaxaad kooban ka bixinayaa:

- Sababta uu uga qaybgalayo koorsada.
- Meesha ay bulshada uga shaqayso ama uga dhex nooshahay.

Isbaridahaa ka dib, wuxuu baruuhu dulmarayaa sida ay isugu dhex qaybsan yihiin ka qaybgalayaasha waxaanu gardaadinayaa wadahalad kooban oo ku saabsan sida xirfadaha isbarashada lagu sheegtay ay wax u geli karaan markii ay musiibo dhacdo markiiba ka dib. Inta uu hadalku socdo, wuxuu baruuhu adkaynayaa muhiimadda war-isgaarsiinta, aaminidda, iyo wadashaqaynta (oo ay tan guud ka fiican tahay tan gaarka ah) tanina waxay tahay shay aad muhiim ugu ah CERTyada waxgalka ah.

Dabadeed, baruuhu wuxuu daaddihinayaa wadahaladka khatar (aha) waaweyn ee bulshadu ay ku jirto iyo saamaynaha ay ku yeelan karaan kaabayaasha bulshada iyo adegyada gurmada.

Dabadeed wuxuu baruuhu daaddihinayaa wadahalad ku saabsan noocyada haliseed ee guryaha iyo dululaatiyada ah ee ay ka qaybgalayaashu ku wajihi karaan iyo noocyada dhisme ee bulshada ku dhex yaal iyo sida khatarahaas loo dhimi karo iyadoo dedaal diyaarsanaaneed oo shaqsi iyo mid bulsho guriga iyo goobta shaqadaba laga hirgelinayo

Ugu dambayn, baruuhu wuxuu soo koobkoobayaa xisadaha muhimka ah ee casharka isagoo samaynaya muuqaalka ah in iyagoo CERT ah awgeed ay ka qaybgalayaashu door wax ku ool ah ka ciyaaraan jawaabcelinta musiibada.

WAXYAABAHA LOO BAAHAN YAHAY

- *Tilmaanta Macallinka ee Kooxda Kajawaabidda Xaaladda Degdegga ah ee Bulshada*
- *Buugga Ardayga ee Kooxda Kajawaabidda Xaaladda Degdegga ah ee Bulshada*
- Muuqaallada 1.1 ilaa 1.22
- Muuqaallada noocyada khataraha ah oo lafa xushay Lifaafa 1-A

QALAB

Qalabka soo socda ee dheraadka ah ayaa loo raba cutubkan:

- Kombiyuutar leh barnaamijka PowerPoint
- Kombiyuutar borojektar leh ama shaashad weyn
- Maqasyo (1 xabbo 5tii ka qaygaleba)
- Sharooto (1 duubro 5tii ka qaygaleba)
- Laba cad oo baakad ah (qiyaasta 8" X 10")(1 sed ah 5tii ka qaygaleba)
- Afartan cad oo xaashida dhismaha ah (8½" x 11") (1 sed ah 5tii ka qaygaleba)

DIYAARGAROW Diyaarso shuruucda Gobolka iyo kuwa maxalliga ah ee dhawra xubnaha CERT ee aaggaaga jooga.

Si taxaddar leh u muraajicee cutubkan iyo qaababka khataraha ee ku qoran dhamaadka cutubkan. Xulo kharataha halista ugu weyn ku haya bulshadaada, kana dhig hal cutub. Hadday suuroggal tahay tusaalayaashaada ku xarar dhacdooyin iyo sawirro maxali ah



OGEYSIINNO Qorshe waqtiyeedka loo gartay cutubkani waa sida soo socota:

Soo dhaweyn iyo Arar	20 daqiiqo
Isbarid iyo Dulmarka Cutubka	5 daqiiqo
Gurmadyadii iyo Musiibooyinkii Dhawaan Dhacay	15 daqiiqo
Milicsiga Koorsada	5 daqiiqo
Musiibada iyo Kuwa Ka Shaqeeya	5 daqiiqo
(Halisaha Musiibada) [Ka timid Lifaafa 1-A]	(25 daqiiqo)
Saamaynta Kaabayaasha ku Timaadda	10 daqiiqo
Khataraha Dhismayaasha iyo Dululaatiga	10 daqiiqo
Dhimidda Khatarta	15 daqiiqo
Diyaarsanaanta Hoyga iyo Goobta Shaqada	15 daqiiqo
Diyaarsanaanta Bulshada	10 daqiiqo
Ilaalinta Ka Shaqeeyayaasha Musiibada	5 daqiiqo
Gebagebada Cutubka	

Wadarta Waqtiga: 2 saac 30 daqiiqo

SOO JEEDIN Cutubkani waxaa ku jira xog ku saabsan khatarodhawr ah oo ay qaar — dhamaan maaha—ay saamayn ku yeelan karaan bulshadaada. Si taxadar leh u muraajicee cutubkan iyo qoraallada wehliya ka hor tababbarka si aad u ogaato khataraha halista ku ah bulshadaada.

Ka dib markaad go'aansato bandig haliseedka aad ku darayso, waxaad u baahan doontaa in aad ku dartid bogaggaaga PowerPoint faylka guud ee Cutubka 1. Si aad isugu mishi bogagga bandhigga:

1. Fur faylka PowerPoint ee Cutub 1.
2. U fur faylka PowerPoint ee aad doonayso in aad ku darto.
3. Inta aad ku jirto bandhigga halista riix “Slide Sorter View” () oo ku yaal dhinaca bidixe ee hoose ee shaashadda.
4. Riix “Edit” oo ku yaal dhinaca sare ee shaashadda.
5. Riix “Select All” oo ku taal taxanta ka soo degtay kobta “edit” ay ku taal.
6. Riix “Window” oo ku yaal dhinaca sare ee shaashadda oo dooro soo jeedinta Cutub 1.
7. Riix “Slide Sorter View” ().
8. Biliglaha ku dulqabo meesha aad ka gelin lahayd halista adigoo riixaya inta u dhexaysa bogagga oo ah meesha ku habboon bandhigidda Cutubka 1.
9. Midig riix, oo dooro “paste” si aad u xerayso bogagga halista.
10. Ku soo celi talaabooyinka 2 ilaa 8 bandhig kasta oo haliseed ee aad doonayso in aad cutubkan ku darto.

CUTUBKA 1: U DIYAARSANAANTA MUSIIBADA



**U ARARO
(GUUD MAR)
KOORSADA**

Soo DHAWEYN IYO ARAR

Ku soo dhawee ka qaybgalayaasha tababbarka Kooxda Kajawaabidda Xaaladda Degdegga ah ee Bulshada.

Isbarta dadka, bixina xog taariikheed yar oo ku saabsan khibradahaaga gurmada ka-jawaabidda.

U sheeg ka qaybgalayaasha in qaybta soo dhaweynta ee Buuggooda Ka Qaybgalayaashu uu ku jiro war sax ah oo ku saabsan:

- Markay Musiibo dhacdo.
- Diyaarsanaanta Bulshada.
- Sida ay u hawlgalaan kooxaha CERT.
- Barnaamijka tababbarka CERT.

Ku dhiirriggeli ka qaybgalayaasha in ay muraajiceeyaan xogtan ka dib markii xisaddan tababbarku la joojiyo.

IS BARIDDA KA QAYBGALAYAASHA

Inta ayba imanayaan ka qaybgalayaashu, samayso taxane fasal adigoo waraaq wareejinaya. Ka codso ka qaybgalayaashu in ay qoraan magacooda, cinwaankooda, iyo lambarka telefoonkooda.



**GUUD MAR
CUTUBKA**



HAWL QABO

HAWL: DHISIDDA TAALLO

Tilmaamaha: Raac tallaabooyinka hoose si aad layliga u samaysid:

1. Ka dhig ka qaybgalayaasha kooxo shan shan ah.
2. U qaybi alaabta soo socota koox kasta:
 - 1 xabbo oo maqas ah
 - 1 doob oo koollo iskoj ah
 - 2 cad oo baaka ah (qiyaasta 8" x 10")
 - 40 cad oo xaashida dhismaha ah (8½" x 11")
3. U sheeg koxda in ay 10ka daqiiqo ee soo socoto ku qaadan doonaan qorshaynta iyo naqshadaynta taallo iskeed u taagan oo ugu yaraan shan fiid jooggeedu yahay kor ilaa hoos. Sharax in ay aad kooxda u sheegi doonto in ay billaabaan ayna haysan doonaan 5 daqiiqo oo halkaa ka billaabata oo ay taallada ku dhisaan
4. U sheeg kooxda in ay hawsha bilaabaan dabadeedna ay joojiyaan.
5. Dhamaadka waqtiga la qoondeeyey, kooxdu ha ka wada hadasho waxay ka barten layliga. Hubi in aad qodobbadan soo socda ka hadashay:
 - Dad aan is aqoon. . .
 - Ka shaqayn kara dhib aysan aqoon. . .
 - Iyagoo isticmaali qalab aysan aqoon. . .
 - Meelo aysan aqoon. . .
 - Bay'ad waqtigeedu ciriiri yahay. . .
 - Si loo fuliyo hal himilo ah.

Carrabka ku adkee in xirfadaha iyo awoodaha ay kooxdu isticmaashay waqtigii layliga ay tahay xirfadaha ay isticmaali doonaan markay xubno CERT yihiinna.



**BANDHIG
MUUQAAL**

ISBARID IYO GUUD-MAR

HIMILOOYINKA CUTUBKA

Himilada Cutubka

- Qeex khataraha ay umaddaadu u dayacan tahay.
- Qeex waxqabadyada CERTyada.
- Aqoonso tallaabooyinka diyaarsanaanta.

Dhamaadka cutubkan, ka qaybgalayaashu waa in ay awoodaan:

- Qeex noocyada khataraha ee ay u badan tahay in ay saameeyaan guryahoda iyo bulshooyinkooda.
- Qeex hawlqabashooyinka CERTyada iyo doorarkooda jawaabidda degdegga ah.
- Aqoonso tallaabooyinka loo qaado si loogu diyaargarobo musiibooyinka.



**MAWDUUCA
SHEEG**



**BANDHIG
MUUQAAL**

GURMADYADII IYO MUSIIBOYINKII MAR DHAW DHACAY

Carrabka ugu adkee ka qaybgalayaasha in:

- Dadka ka jawaaba gurmadyada waxay u wada shaqeeyaan heerar kala duwan si ay u yeeshaan awoodo waxtar oo degdeg ah.
- Awoodaha adeegga gurmada waxaa si weyn loogu sii hagaajin karaa CERTyada sida fiican loo mareeyey, loo tababaray, lana isugu dubbarridey ee awoodda u leh in ay:
 - Si hordhac ah ugu diyaar-garoobaan dhacdo musiibo.
 - Jawaab-celin gurmada ka bixiyaan oo wax ka qabtaan baahida degdegga ah ee bulshadooda oo ay musiibadu keentay.

U Diyaargarowga Musiibo

CERTyadu waa in ay diyaar-garoobaan iyagoo:

- Sii aqoonsanaya khataraha ka dhici kara guryahooda iyo goobahooda shaqo.
- Yaraynta khataraha, markay suuroggal tahay.
- Samaysiga guntin sahay musiibo.

U sheeg ka qaybgalayaasha, ka xubno CERT ahaan, in doorkoodu yahay in ay u diyaargarooobaan musiibo iyagoo:

- Aqoonsanaya khataraha dululaati iyo dhisme eek a dhici kara guryahooda iyo goobahooda shaqo.
- Yaraynta khataraha ilaa xadka ugu suuraggalsan inta aanay musiibadu.
- Samaysiga guntin sahay musiibo



XUSUUSINTA
MACALLINKA



BANDHIG
MUUQAAL

GURMADYADII IYO MUSIIBOYINKII MAR DHAW DHACAY (WELI SOCDA)

U sheeg ka qaybgalayaasha in liis dhamaystiran oo ashyaa'da lagu daro guntinta sahay musiibo ahi uu cutubkan gadaal uga jiro waana Daabacad ay FEMA leedahay oo cinwaankeedu yahay, *Ma Tahay Diyaar?*, oona laga heli karo websaytka FEMA oo ah: www.fema.gov/areyouready/ oo Word iyo PDF-ba ah.

U Jawaabidda Musiibo

CERTyada waa in ay ku jawaabtaa:

- Helidda iyo deminta yutiilitida, hadday nabdoon tahay arrintaasi.
- Bakhtiinta dababka yaryar.
- Daweynta dhaawacyada.
- Samaynta goobid iyo samatabbixin khafiif ah.
- Caawinta dhimidda buufiska waareyaasha.

CERTyada waxay jawaabaan musiibo dabadeed iyagoo:

- Helaya oo deminaya yutiilitida, hadday nabdoon tahay.
- Bakhtiinta dababka yaryar.
- Daweynta dhaawacyada naf-gooyada ah inta ay caawin xirfadaysan laga helayo.
- Samaynta goobid iyo samatabbixin khafiif ah.
- Caawinta dadka ka waaray musiibooyinka si ay ula qabsadaan buufiskooda dhimirka ah.

**GURMADYADII IYO MUSIIBOYINKII MAR DHAW DHACAY
(WELI SOCDA)**

Si kooban u dulmar musiibooyinka iyo gurmadyada ka dhacay aaggaaga ama Gobolkaaga. Ka hadal:

- Dhacdada (tus., Harikeyn Caynka 4 ah, dhulgariir qiyaastiisu tahay 6.3).
- Burburka (tus., dadka dhintay, dhaawacyada, qiimaha dib-u-dhiska).
- Casharada la bartay, gaar ahaan sida ay ugu tacalluqaan diyaarsanaanta.

Dabadeed sharax doorka CERTyada ay qaadan kari lahaayeen haddii ay hawl-geli karayeen waqtiga musiibada. La xiriiri doorkooda hawlqabadka muhimka ah ee CERT:

- Ka-nabdoonaanta dabka
- Hawlgallada caafimaadka
- Goobid iyo samatabbixin khafiif ah
- Cilmu-nafsiga Musiibada

CERTYADA IYO DOORARKA MUSIIBADA

Sharax in ay jiraan dhawr jeer oo ay xubnaha CERT ka qaybqaataan kajawaabidda musiibada.

Tilmaan in intii lagu jirey Dhulgariirkii Northridge, sida soo socda ayaa CERT loo isticmaalay:

- Goobid: 203
- Samatabbixin: 17
- Daweyn Caafimaad: 57
- Daad-gurayn bukaan: 4
- Dab xakamayn: 5
- Xakamaynta yutiilitida: 156

**GURMADYADII IYO MUSIIBOYINKII MAR DHAW DHACAY
(WELI SOCDA)**

U sheeg kooxda in Alachua County, FL, waqtigii lagu jirey ee harikeyntii Floyd ee 1999 iyo intay socotay Duufaano Jiilaaleedkii Gordon ee 2000, CERTyada waxaa u yeeray EOC si ay ula xiriiraan degganayaasha qaba baahida khaaska ah si ay u xaqiijiyaan in ay og yihiin in ay duufaano soo socdaan iyo in ay hubiyaan in ay dadkaasi doonayaan in ay isticmaalaan hoyga iyo gaadiidka gobolka ee dadka baahida khaaska ah leh loogu talaggalay. CERTyadaa isku duway gaadiid, meeshii looga baahday.

Ilaa daraasiin CERTyo ah ayaa la isticmaaqalay intii lagu jirey dababkii Hidden Lake iyo Lake Louise ee dhacay 2000 si ay cunto u siiyaan dabdemiyaasha, sahaydana ay guraan, oo ay caawinna ka geysato diyaar-garowga aagga.

U sheeg kooxda in ra'yiga CERT ay ka fidday ujeeddadeedii hore ee asalka ahayd ee ahaa hawlgal jawaabeed ka dib markii ay dhacay musiiibooyin halaag leh. CERTyada hadda waxaa loo hawlgeliyaa noocyo badan oo musiiibooyin ah. Tusaale ahaan, Whatcom County, WA, xubnaha CERT ayaa loogu yeeray xaaladaha soo socda:

- Qarixii tuubbada gaaska ee Whatcom Creek (Olympic Pipeline)
- Qarixii ka dhacay Georgia-Pacific Pulp & Paper Mill
- Hawlgelintii Xarunta Hawlaha Gurmada(EOC) ee Y2K
- Dhacdadii daadka iyo dabaysha ee Sandy Point
- Dhulgariirkii Nisqually

Xubnaha CERT ee ka jawaabay dhacdadii Whatcom Creek waxay waxqabadkooda awgii heleen Billadda *The American Red Cross Real Heroes Award*. Xubnaha CERT ee degmada waxay heleen aqoonsi Federaal, Gobol, iyo maxalli ah oo ay ku heleen dedaalladoodii iyo wax-qabadkoodii.



BANDHIG
MUUQAAL

**GURMADYADII IYO MUSIIBOYINKII MAR DHAW DHACAY
(WELI SOCDA)**

DOORARKA CERTYADA EE MUSIIBO MARKAANAY JIRIN

Doorarka CERT ee Musiibada markaanay jirin

Xubnaha CERT waxay yeeli karaan in:

- Ay qaybiyaan alaabo diyaarsanaaneed.
- Shaqaale ka noqdaan cooshadaha gargaarka kowaad iyo dhacdooyinka khaaska ah.
- Wax ka geystaan rakibidda gambaleelka qiiqa ka diga.

U sharax xubnaha CERT in ay kaloo jiraan gole mutaddawaciin oo bulshadu leedahay. Waxay wax ka tari karaan mashaariicda sida:

- Qaybinta alaabta diyaarsanaanta.
- Shaqaale ka noqoshada cooshadaha dawada marka lagu jiro dhacdooyinka khaaska ah.
- Caawinta u rakibidda gambaleelka qiiqa ka diga waayeelka iyo qoysaska dadka baahida khaaska ah qaba.



**BANDHIG
MUUQAAL**

**GURMADYADII IYO MUSIIBOYINKII MAR DHAW DHACAY
(WELI SOCDA)**

Jaallayaasha Muwaaddiniinta

- Madaxweynaha ayaa Maraykanka dadkiisa ku dhiirrigeliyey in ay mutaddawacnimo ku shaqeeyaan si ay u hagaajiyaan una ilaaliyaan qaranka.
- Aagagga muhiimka ah ee dedaallada mutadawiciinta:
 - Dembi
 - Musiibooyinka dabiiciga ah
 - Argaggixisannimada

Waxaa dheeraad ah, in qudbadiisii Xaaladda Dalka ee Janaayo 29, 2002, Madaxweynaha ayaa dadka Maraykanka ah weydiistay in ay muddawacaan oo u adeegaan dhawraanna dalka. Aaggagga sadexda ah ee ay dedaalladaa mutaddawacnimada ah diiradda saaraan waxa weeye dembi, musiibo dabiici ah, iyo argaggixisannimo. Barnaamijka “The Citizen Corps” waxaa loo abuuray in ay Maraykanka ka cawiyaan dhawaaqaas adeeg. Mid ka mid ah fursadaha mutaddawacnimada ee bulshada Maraykanka ah lagu siiyo dallada “Citizen Corps” waa barnaamijka CERT.



**XUSUUSIN
MACALLINKA**

Haddii uu qof weydiyo, sharax in fursadaha kale ee Citizen Corps ay sameeyaan waxaa ka mid ah Deris Dhawrida “Neighborhood Watch,” Mutaddawiciinta Adeegga Bilayska “Volunteers in Police Service,” iyo Medical Response Corps. Jaalleyaasha wax Daweeya waqtiga Gurmadka.



BANDHIG
MUUQAAL

**GURMADYADII IYO MUSIIBOYINKII MAR DHAW DHACAY
(WELI SOCDA)**

**Fursadaha Tababbarrada ee Dgeeraadka ah ee
CERT**

- Maaraynta hooyga
- Xiriirka bulshada
- Maaraynta deeqaha
- Walaacyada baahida khaaska ah
- Qashin ururinta
- Xakamaynta yutiilitida
- Gargaarka kowaad ee horumarsan
- Isticmaalka Diflabratoorka Otomaatigga ah ee Sare (Automated External Defibrillator)
- Xirfadaha CPR

Dhamaynta tababbarka bilowga ah ee CERT ka dib, xubno badan oo CERT ah aya doona in ay fidiyaan oo hagaajiyaan xirfadahooda—iyagoo qaababka CERT ee maxalli ahaanta ay Laanqayrta Case e Maraykanka u bixiso sii wadaya ama barnaamijyo ilo kale ah. Xubnaha CERT qaar ayaa fursado tababbar oo dheeraada u raadsaday:

- Maaraynta hooyga
- Xiriirka bulshada
- Maaraynta deeqaha
- Walaacyada baahida khaaska ah
- Qashin ururinta
- Xakamaynta yutiilitida
- Gargaarka kowaad ee horumarsan
- Isticmaalka Diflabratoorka Otomaatigga ah ee Sare (Automated External Defibrillator)

- Xirfadaha CPR

Ask the participants if they have any questions about the use of CERTs in recent disasters.

U sheeg ka qaybgalayaasha in marka xiga aad guud-mar ka bixin doontid koorsada.



**BANDHIG
MUUQAAL**

GUUD-MARKA KOORSADA

Sharax in cutubkani uu bixin doono guud-marka koorsada isagoo meel loogu soo hagaago u dejinaya CERTyada marka ay taagan tahay khatar khaas ah oo ay bulshadu wajahayso.

Guud-marka Koorsada

Wajahadda koosadan wax aka mid ah:

- Ka nabdoonaanta dabka.
- Hawlgallada caafimaad ee musiibada.
- Goobid iyo samatabbixin khafiif ah.
- Qaab-dhismeedka CERT.
- Cilmu-nafsiga musiibada.
- CERTyada iyo argaggixisanimada.

U sheeg kooxda in cutubyada dambe ay ka hadli doonaan:

- Ka nabdoonaanta dabka.
- Hawlgallada caafimaad ee musiibada.
- Goobid iyo samatabbixin khafiif ah.
- Qaab-dhismeedka CERT.
- Cilmu-nafsiga musiibada.
- CERTyada iyo argaggixisanimada

Samee wixii ogeysiin maamul ah oo waqtigan loo baahan yahay. Ku dar xog ku saabsan:

- Waqtiyada xisaddan iyo kuwa mustaqbalka.
- Alaabta loo baahan yahay.
- Dhisidda guntimaha u diyaarsanaanta musiibada.
- Marinnada degdegga looga baxo.
- Meelaha musqulaha, siyaasadda sigaar-cabidda, iwm.
- Shuruudaha dhamaystiridda koorsada.



**BANDHIG
MUUQAAL**

MUSIIBOYINKA IYO DADKA KA SHAQEEYA

Noocyada Musiibooyinka

- Dabiici
- Dad-samee
- Tiknoolojiyadeed



**SHEEG
MAWDUUCA**

Furfur qaybtaan adigoo sheegaya in ay musiibooyinku noqon karaan:

- Dabiici
- Dad-samee
- Tiknoolojiyadeed.



**BANDHIG
MUUQAAL**

Walxaha Ugu Muhiimsan Musiiboyinka

- Waa kuwo aan la rajeynaynin.
- Shaqaalaha gurmada farahooday ka badan kartaa.
- Nafo, caafimaad, iyo bay'addaba halis bay gelisaa.

MUSIIBOYINKA IYO DADKA KA SHAQEEYA (WELI SOCDA)

Sharax in wax kastaa ha noqoto dhacdadee, ay musiibooyinku walxaha dhawr ah oo muhiim ah wadaagaan:

- Waxay yihiin kuwa aan loo fadhiyin inta badan, mana leh ama waa yar yihiin digniinta iyo fursadda diyaar-garobaba.
- Shaqaalaha iyo adeegyada gurmada marka hore farahooday xaaladdu ka bixi kartaa, dalab ku saabsan adeegyadooda awgiis.
- Nafo, caafimaad, iyo bay'addaba halis bay gelisaa.

Adkee in marka ay musiibo dhacdo wax yar ka gadaal, baahidu way ka badan doontaa xadka ay bixin karaan shaqaalaha xirfadda leh ee adeegyada gurmada. Mararkaas, CERT ayaa noqota nudka ugu muhiimsan ee isku xira silsiladda adeegga gurmada.

KHATARAHA MUSIIBADA

Soo bandhig xog ku saabsan khataraha halista ugu badan gelin kara bulshadaada halkan deggan.



XUSUUSIN
MACALLINKA



SHEEG
MAWDUUCA



PM, P. 1-6

RAAD-REEBKA KAABAYAASHA KU HARA

Weydii ka qayb-galayaasha intee iyaga ka md ah oo ay qabsatay [halkan geli halista degaankan u badan]. Weydii noocyada dhibaato eek u dhacday sida waxay kala kulmeen yutiilitida iyo gaadiidka.

U dir ka qayb-galayaasha shaxda cinwaankeedu yahay, *Raadreebka Suuraggalka ah ee ku dhici Kara Kaabayaasha*, eek u qoran Buugga Ardayga. Soo koob jawaabaha ka qayb-galayaasha ay ka baxsheen su'aalaha adoo taxaya raadreebyada ku hara kaabayaasha.



PM, P. 1-6

Raadreebka Suuraggalka ah ee Burbur ee ku dhici Kara Kaabayaasha

Burbur ku dhaca . . .	Saamaynaha Suuraggalka ah
Gaadiidka	<ul style="list-style-type: none"> ▪ Awood la'aan in si sax ah loo qiimeeyo burburka. ▪ Ambalaasyada oo meesha gaari waaya ▪ Bilayska oo ka xanibma meesha ay ka dhacday qalalaasada shicibka ▪ Dabdemiska oo ka xannibma gaaridda dabka ▪ Qulqulka sahaydii loo baahnaa oo kala go'a
Dhismayaasha	<ul style="list-style-type: none"> ▪ Isbitaallo burbursan oo si caadi ah u shaqayn waaya ▪ Khatar ka soo korodha burburka soo daadanaya
Habka War-is-gaarsiinta	<ul style="list-style-type: none"> ▪ Dhibbanayaasha oo kaalmo u wacan waaya ▪ Agaasinka adeegyada oo kharribma
Yutiilitida	<ul style="list-style-type: none"> ▪ Yutiilitida (gaaska, biyaha, iwm) oo go'a ▪ Khatar ka soo korodha koranto iyo dab shil leh ▪ Wada xiriirka dhibbanayaasha iyo adeeg bixiyayaasha oo dhuma ▪ Sahay biyo oo aan ku fillayn ▪ Khatar ka soo korodha caafimaadka bulshada ee guud
Adeegga Biyaha	<ul style="list-style-type: none"> ▪ Awoodaha dab-deminta oo xaddidma ▪ Tas-hiilaadka caafimaad oo kharribma
Sahayda Shidaalka	<ul style="list-style-type: none"> ▪ Khatar ka soo korodha dab ama qarax ka yimaada tuubbo shidaal oo dillaacda ▪ Khatar cabburid/neef xiran ah



BANDHIG
MUUQAAL

RAAD-REEBKA KAABAYAASHA KU HARA

Raad-reebka ku Yimaada Kaabayaasha

Burbur ku dhaca gaadiidka:

- Awood la'aan in si sax ah loo qiimeeyo burburka.
- Ambalaasyada oo meesha gaari waaya
- Bilayska oo ka xanibma meesha ay ka dhacday qalalaasada shicibka
- Dabdemiska oo ka xannibma gaaridda dabka
- Qulqulka sahaydii loo baahnaa oo kala go'a

Burbur ku yimaada gaadiidka wuxuu keeni karaa:

- Awood la'aan in si sax ah loo qiimeeyo burburka.
- Ambalaasyada oo meesha gaari waaya
- Bilayska oo ka xanibma meesha ay ka dhacday qalalaasada shicibka
- Dabdemiska oo ka xannibma gaaridda dabka
- Qulqulka sahaydii loo baahnaa oo kala go'a



**BANDHIG
MUUQAAL**

RAAD-REEBKA KAABAYAASHA KU HARA (WELI SOCOTA)

Raad-reebka ku Yimaada Kaabayaasha

Burbur ku dhaca dhismayaasha:

- Isbitaallo burbursan oo si caadi ah u shaqayn waaya
- Khatar ka soo korodha burburka soo daadanaya

Burbur ku dhaca dhismayaasha wuxuu:

- Isbitaallada burburay ka celin karaa in ay qabtaan bukaannada.
- Khatar ka soo korodhin karaa burburka soo daadanaya



**BANDHIG
MUUQAAL**

Raad-reebka ku Yimaada Kaabayaasha

Warisgaarsiin kala go'day waxay:

- Dhibbanayaasha oo kaalmo u wacan waaya
- Agaasinka adeegyada oo kharribma

Warisgaarsiin kala go'day waxay:

- Dhibbanayaasha oo kaalmo u wacan waaya
- Agaasinka adeegyada oo kharribma



**BANDHIG
MUUQAAL**

RAAD-REEBKA KAABAYAASHA KU HARA (WELI SOCOTA)

Raad-reebka ku Yimaada Kaabayaasha

Burbur ku yimaada yutiilitida waxay keeni:

- Yutiilitida (gaaska, biyaha, iwm) oo go'a
- Khatar ka soo korodha koranto iyo dab shil leh
- Wada xiriirka dhibbanayaasha iyo adeeg bixiyayaasha oo dhuma
- Sahay biyo oo aan ku fillayn
- Khatar ka soo korodha caafimaadka bulshada ee guud

Burbur ku yimaada yutiilitida waxay keeni:

- Yutiilitida (gaaska, biyaha, iwm) oo go'a
- Khatar ka soo korodha koranto iyo dab shil leh
- Wada xiriirka dhibbanayaasha iyo adeeg bixiyayaasha oo dhuma
- Sahay biyo oo aan ku fillayn
- Khatar ka soo korodha caafimaadka bulshada ee guud
- (haddii uu jiro burbur ballaaran oo biyaha ah ama ay sumoobaan).



BANDHIG
MUUQAAL

RAAD-REEBKA KAABAYAASHA KU HARA (WELI SOCOTA)

Raad-reebka ku Yimaada Kaabayaasha

Burbur ku yimaada sahayda shidaalka:

- Khatar ka soo korodha dab ama qarax ka yimaada tuubbo shidaal oo dillaacda
- Khatar cabburid/neef xiran ah

Burbur ku yimaada sahayda shidaalka:

- Khatar ka soo korodha dab ama qarax ka yimaada tuubbo shidaal oo dillaacda
- Khatar cabburid/neef xiran ah oo ka yimaada gaas ku liigay meelaha xiran

Macnee xiriirsanaanta ku tacalluqda in wax kasta oo burbur ahoo dhaca ay si ba'an u xaddidi karaan awoodda bilayska, dabdemiska, iyo adeegyada gurmada ee caafimaad ay ku gaari karaan musiibadaas.

Tilmaan in sababta ah in ay shaqaalaha adeegga gurmada haysan karaan sahay gargaar oo aan ku fillayn in ay bulshada wada gaarto, markaana ay tahay in sahayda loo qaybiyo sida loo kala mudan yahay.

- Bilaysku waxay wax ka qabanayaan dhacdooyinka nabdoonaanta bulshada saamayn khatar ah ku keeni karta.
- Dandemisyaduna waxay xakamaynayaan dababka waaweyn.
- Shaqaalaha EMS ayaa wax ka qabanaya dhaawacyada naf-gooyada ah. (Si kastaba ha ahaatee carrabka ku adkee in CERT ay sidoo kale wax ka sii qabato dhaawacyada naf-gooyada ah inta aanay unogyada EMS meesha iman.)

Baahiyada kalee muhimada hooseeya si kale ayaa loola xaali.



SHEEG
MAWDUUCA



WEYDII SU'AAL

KHATARAHA DHISMAYAASHA IYO DULULAATIGA

Mawduucan ku furfuro weydiinta su'aalo ku saabsan halisyada hoose.

Intee idinka mid ah oo taqaana meesha uu ku yaallo demiyaha yutiilitidaada?

U isticmaal jawaabaha ka qayb-galayaasha si aad u keento eray-bixinta dhimidda khataraha. U sheeg in deminta ama laalidda yutiilitidu ay tahay hal jid ah oo lagu yareeyo – ama lagu dhimo— halista inta aanay musiibadu dhicin. Deminta yutiilitida iyadu waa halka jid ee la hubo inuu yareeyo halista musiibo marka dhacdo dabadeed oo u dhaw.

Sharax in tallaabooyinka yaraynta oo uu qof qaado musiibada ka hor ama marka ay dhacdaba in ay ku xiran tahay halista iyo nooca dhismaha. Mawduucani wuxuu ka hadli doonaa noocyada dhismayaasha iyo khataraha mid kasta la xiriira. Tallaabooyin taxadar ah oo ay ku jirto dhimista khatarta ee dhismayaasha iyo dululaatiyada ayaa la qaadan doonaa marka tan xigtana.

KHATARAHA LA XIRIIRA NOOCA DHISMAHA

Xusuusi ka qayb-galayaasha in aysan dooran karayn nooca dhisme ee ay ku jiraan marka ay musiibo dhacdo. Wa muhiim in la ogaado noca burbur ee laga filan karo noocyada dhismayaasha a eek u dhex yaalla bulshada.

U sheeg ka qaybgalayaasha in dhismayaasha la injiyeer-gareeyey sida guryaha aadka u dheer-dheer in ay ugu fiicnaayeen markii ay dhacaan inta badan musiibooyinku. Carrabka ku adkee in marar ay dhaceen dhulgariirro iyo dhacdooyinka dabaylaha sare (sida toornaadooyinka, harikeynada) in dhismayaasha dhaadheer ee gaboobey ay u badnayd in uu dhib ka soo gaaro:

- Quraarado burburay.
- Gidaarro soo dhaca.
- Wadiiqo dhismeedyo iyo luuq soo duma.



WEYDII SU'AAL

KHATARAHA DHISMAYAASHA IYO DULULAATIGA (WELI SOCDA)

**Meeqaa idinka mid ah oo ku nool guri qoys keliya?
Ma taqaan nooca burbur ee aad filanayso?**

Haddii aanay soo qaadin kooxdu, u sheeg in da'da, nooca dhismaha, iyo nooca musiibadu ay yihiin saameeyayaasha waweyn ee burburka ku dhici kara guryaha teedan iyo garaashyada.

- Guud ahaan guryaha la dhisay ka hor 1940 kuma ay qodbana asaaskooda taa oo uu ka dhigaysa kuwo gilgilan kara, biibi kara, ama ka ruqaansan kara asaaskooda.
- Guryaha waaweyn oo ka dhisan bulukeetiga aan la xoojinin ayaa ka degganaansho yar dhismayaasha cusub.

Xusuusi ka qaybgalayaasha in:

- Burburka tornado iyo harikeyn ay ku sameyaan guryaha halka ah aysan marna wax u dhimi karin marna ay wada dumin karaan.
- Ka dib dhacdo burburisay dhisme, waxaa halis loogu jiraa in ay dhib kale dhacdo sida dab ka dhashay tuubbada gaaska oo dillaacday.



WEYDII SU'AAL

KHATARAHA DHISMAYAASHA IYO DULULAATIGA (WELI SOCDA)

**Meeqaa idinka mid ah oo ku nool guri qoys keliya?
Ma taqaan nooca burbur ee aad filanayso haddii ay dhacdo halis heer sare ah?**

Haddii aanay soo qaadin ka qaybgalayaashu, sheeg in giryaha guurguura ay ugu jiraan halis burbur mar haddii ay si sahlan u salkici karaan. Marka ay salkicid dhacdo, wadajirka dhismahaa ayaa noqonaya mid suaali ka taagan tahay, waxaa si sahlan u googgo'l kara isku xirkii yutiilitida, waxaanay taasi badanaysaa khatarta dab iyo shook dhinaca korantada ah.

Tilmaan in moolalka, meelaha isboortiga, madaarrada, meelaha cibaadada iyo meelo kale oo badan oo leh saqaf dheer ay halis keeni karaan markii ay dhacaan qaar ka mid ah musiibooyinka. Tusaale ahaan:

- Xarumaha ganacsiga ee safan waxay halis ka keenaan dumis iyo quraarado burbura.
- Dhismayaasha u samaysan nooca bakhaarrada waaweyn iyaguna way dumi karaan.

Ku dar in sidoo kale ay jiri karto khatar ku dhacda dhamaan dhismayaasha iyo dululaatiyada.

KHATARAHA DULULAATYADA (MEELAHA AAN DHISMAHA AHAYN)

Meeqa idinka mid ah oo ka warqabta khataraha guryihiinna iyo meelihiinna shaqada?

Haddaanay kooxdu soo qaadin, carrabka ku adkee in cid waliba ay halis ku wajahayso gurrigeeda iyo meelaheeda shaqada. Waxyaabaha ku rakiban ama alaabta guri, garaash, ama meel shaqo taalla waxay keeni kartaa halis marka lagu jiro am aka dib musiibo.



WEYDII SU'AAL



BANDHIG
MUUQAAL

KHATARAHA DULULAATYADA (MEELAHA AAN DHISMAHA AHAYN) (WELI SOCDA)

Khataraha Ka Yimaada Waxyaabaha ku Rakiban Guryaha

- Dillaaca tuubooyinka gaaska oo ka yimaada kululeeyayaasha biyaha ama burjikooyinka waaweyn
- Burbur ka yimaada bug, weelal, ama waxyaabo armaajaadka ku jira oo soo daadanaya
- Koranto qabasho ka yimaadi fiilooyin dubkacay
- Dab ka ymid xiritaan koranto oo khaldan, bareesyo buuxdhaafay, ama fiilo karanto oo shiilantay

Qaar ka mid ah khataraha waxaa ka mid ah:

- Dillaaca tuubooyinka gaaska oo ka yimaada kululeeyayaasha biyaha ama burjikooyinka waaweyn
- Burbur ka yimaada bug, weelal, ama waxyaabo armaajaadka ku jira oo soo daadanaya
- Koranto qabasho ka yimaadi fiilooyin dubkacay
- Dab ka ymid xiritaan koranto oo khaldan, bareesyo buuxdhaafay, ama fiilo karanto oo shiilantay

Adkee muhiimadda yaraynta khatarta oo ah qayb ka mid ah diyaarsanaanta. Adkee in ay jiraan dhawr tallaabo oo sahlan oo ay shakhsiyaadku qqaadi karaan si ay u dhimaan khataraha guryaha iyo goobaha shaqada.



**SHEEG
MAWDUUCA**

DHIMISTA KHATARAHA

Adkee muhiimadda ahaanshada qof og waxyaabaha ay keeni karaan dhacdooyinka iman kara, oo ay ka mid tahay dhacdo argaggixisannimo. Inta ay sii badato xogta ay ka qaybgalayaashu haystaan, waxaa iyana sii badanaysa in ay qorsheeyaan in ay si ku filan u sii qorshaystaan oo ay si macquul ah wax uga qabtaan musiibooyinka.

U sheeg kooxda in, si kasta ha noqoto musiibada iyo digniinta laga baxshaye, waxaa jira taxadarro nabdoonaaneed oo ay qaadi karaan si ay u yareeyaan ama uga hortagaan dhaawac. Qaybtani waxay la xaali doontaa tallaabooyinka lagu xaqiijiyo nabdoonaanta shaqsiyadeed.

Qaybta soo socta waxay wajahaysaa:

- Diyaarsanaanta guriga iyo goobta shaqada.
- Diyaarsanaanta bulshada.

NABDOONAANTA SHAQSIGA AH



WEYDII SU'AAL

Maxaa samayn lahayd haddii ay dibadda kugu qabsato [sheeg nooca haliseed ee caanka ka ah aaggaaga]?

Aqoonso jawaabta kooxda. Dabadeed weydii:



WEYDII SU'AAL

Maxaa samayn lahayd haddii ay dibadda kugu qabsato [sheeg nooc halis ah oo u baahan tallaabooyin kale oo nabdoonaan shaqsiyadeed ah]?



**BANDHIG
MUUQAAL**

DHIMISTA KHATARAHA (WELI SOCDA)

Soo koob wadahadalka adigoo istcmaalaya muuqaalka soo socda.

Nabdoonaanta Shaqsiyadeed

Tallaabooyinka nabdoonaanta shaqsiyadeed way kala duwan yihiin iyagoo ku xiran:

- Nooca dhacdada.
- Inta ay la egtahay digniinta la sii helay.
- Meeshaad joogto markay dhacdo musiibadu (sida, gudaha, bannaanka, gaari wada).

Haddaanay sheegin kooxdu, xusuusi in tallaabooyinka habboon ee nabdoonaanta shaqsiyadeed ay go'aan ka gaarto:

- Nooca dhacdada.
- Inta ay la egtahay digniinta la helay.
- In ay gudaha ku jiraan, bannaanka jiraan, ama gaari wadaan.

Xusuusi ka qaybgalayaasha in ilaalinta naftooda waqtiga lagu jiro musiibo ay u baahan tahay qorshayn. Waxaa jira tallaabooyin ay tahay in ay qaadaan si ay u yareeyaan burburka ay geystan inta badan halisyadu. Tallaabooyinkaan waxaa la qaadi karaa waqti dheer ka hor intaanay musiibo dhicin, inta ay socoto musiibada, ama ka dib musiibada.



**BANDHIG
MUUQAAL**

DIYAARSANAANTA GURIGA IYO GOOBTA SHAQADA

Xusuusi kooxda in diyaarsanaantu ay fure u tahay ka samatabbixidda musiibada. Shaqsiyaadka, qoysaska, iyo maareeyayaasha dhismayaasha waxay qaadi karan tallaabooyin yareeya khataraha dhismayaasha iyo dululaatiyada, waxay sahli karaan fakasho, waxaanay horay u marin karaan samatabbax ka dib markii ay dhacdo dhacdadu.

Diyaarsanaanta Guryaha/Goobaha Shaqada

- Yaraynta khataraha dhismayaasha iyo dululaatiyada
- Diyaarsanaan shaqsi:
 - Isku duwo sahay musiibo.
 - Samayso qorshe musiibo.
 - Samayso qol nabdoon.

U sheeg kooxda in diyaarsanaanta guriga iyo goobta shaqo ay ku jiraan:

- Yaraynta halista dhismayaasha iyo dululaatiyada.
- Diyaarsanaan shaqsi sida:
 - Isku duwashada guntin sahay musiibo.
 - Samaysiga qorshe musiibo.
 - Ka samaysiga qol nabdoon meel ka mid ah meelaha sugan ee guriga (haddii lacalla ay madaxdu ku dhahaan guriga ku jir inta ay musiibo socoto).



PM, P. 1-10

BANDHIG
MUUQAAL**DIYAARSANAANTA GURIGA IYO GOOBTA SHAQADA
(WELI SOCOTA)****YARAYNTA HALISTA DHISMAYAASHA IYO DULULAATIYADA**

U dir ka qaybgalayaasha shaxda ciwaankeedu yahay, *Taxaddarrada Khataraha Dhismayaasha iyo Dululaatiyada*, oo ku qoran Buuggooda Ardayga. Adkee in dhaawacyo badan oo ka yimaada khataraha dhismayaasha iyo dululaatiyada in si sahlan looga hortegi karo.

Muunad Yaraynta Khatarta Dhismayaasha ah

- Ku qodob guryaha duqa ah aasaasyadooda.
- Haamaha baroobaynta “propane” xirxir.
- Dallac yutiilitiyada.
- Guryaha guurguura ku xir asalkooda sibidhka ah.
- Weydiiso xirfadle in uu kuu eego aasaaska, saqafka, xirayaasha saqafka, shooladda qiica, iwm.

Tallaabooyin ay ka qaybqaatayaashu qaadi karaan waxaa ka mid noqon kara kuwa soo socda:

- Muunado khataraha dhismayaasha ah:
 - Ku qodob guryaha duqa ah aasaasyadooda.
 - Haamaha baroobaynta “propane” xirxir.
 - Dallac yutiilitiyada.
 - Guryaha guurguura ku xir asalkooda sibidhka ah.
 - Weydiiso xirfadle in uu kuu eego aasaaska, saqafka, xirayaasha saqafka, shooladda qiica, iwm.

XUSUUSIN
MACALLINKA

Fadlan raadi noocyada khataraha dhisme ee aaggaaga, oo markaa u beddel talaabooyinkan khatar yaraynta kuwo ku habboon degaankaaga.



PM, P. 1-10

Taxaddarrada Ka-hortegidda Khataraha Dhismayaasha iyo Dululaatiyada

Nooca Halista	Taxaddarro Muunad ah
Dhismaha	<ul style="list-style-type: none"> ▪ Ku qodob guryaha duqa ah aasaasyadooda. ▪ Haamaha baroobaynta “propane” xirxir. ▪ Dallac yitiilitiyada. ▪ Guryaha guurguura ku xir asalkooda sibidhka ah. ▪ Weydiiso xirfadle in uu kuu eego aasaaska, saqafka, xirayaasha saqafka, shooladda qiica, iwm.
Dululaatiyada	<ul style="list-style-type: none"> ▪ Gidaarka ku xir faraajiinta sida shelefyada buugaagta, qafisyada, iyo saacadaha waaweyn. ▪ Meel kula dheji qalabyada iyo aaladda xafiiska adoo isticmaalaya <i>Velcro</i>[®] nooca warshadaha ah. ▪ Ku adkee albaabbada kabineetada adkeeyayaal carruurta ka adag. ▪ Hel oo xir gaaska, korantada, iyo biyaha inta aanay musiibadu dhicin. Musiibo ka dib, u xir yutiilitiyada sida loo baahdo si dab iyo khatar kaleba looga hortago. Meel aad ka heli kartid gasho baanadda xiridda yutiilitida. ▪ Gidaarka ku adkee biyo kululeeyayaasha si aad uga ilaaliso tuubbo dildillaacday oo gaas ama fiilo koranto oo debecday.



BANDHIG
MUUQAAL

DIYAARSANAANTA GURYAHA IYO GOOBTA SHAQADA (WELI SOCDA)

Dhimidda Khatarta Dululaatiyada oo Muunad ah

- Xir faraajiinta cul-culus.
- Adkee qalabka iyo aaladda xafiiska.
- Ku adkee albaabbada kabineetada xajiyeyaasha carruurta ka adag.
- Hel oo calamadee meesha laga demiyo gaaska korantada iyo biyaha.
- Adkee biyo-kululeeyayaasha oo rakibo tuubbooyin gaas oo debecsan.

▪ Muunado Khatarta Dululaatiyada ah:

- Gidaarka ku xir faraajiinta culus sida shelefyada buugaagta, qafisyada, iyo saacadaha waaweyn.
- Meel kula dheji qalabyada iyo aaladda xafiiska adoo isticmaalaya Velcro® nooca warshadaha ah.
- S Ku adkee albaabbada kabineetada xajiyeyaasha carruurta ka adag.
- Hel oo xir gaaska, korantada, iyo biyaha inta aanay musiibadu dhicin. Musiibo ka dib, u xir yutiilitiyada sida loo baahdo si dab iyo khatar kaleba looga hortago.
- Gidaarka ku adkee biyo kululeeyayaasha si aad uga ilaaliso tuubbo dildillaacday oo gaas ama fiilo koranto oo debeccday.



PM, P. 1-11

U dir ka qaybgalayaasha shaxda lagu magacaabo *Xiridda Yutiilitiyada* oo ku taal buuggooda adrayda. U sheeg kooxda in ay ku tababbaran doonaan xiridda yutiilitida qaybta soo socota.

Sharax in ay khataraha kala duwan ee dululaatiyadu ay halisyo kala duwan keenaan, iyadoo ku xiran musiibada. Bixi dhawr tusaale oo tallaabooyin ka hortegid ah, una dirk a qaybgalayaasha websaytka FEMA ee *Talking about Disasters* (Ka Hadlidda Musiibooyinka) si xog dheeraad ah ay u helaan: www.fema.gov/rrr/talkdiz/.

KOOXDA KAJAWAABIDDA XAALADDA DEGDEGGA AH EE BULSHADA
 CUTUBKA 1: U DIYAARSANAANTA MUSIIBADA



PM, P. 1-11

Deminta Yutiilitiyada

Electrical Shut-Offs

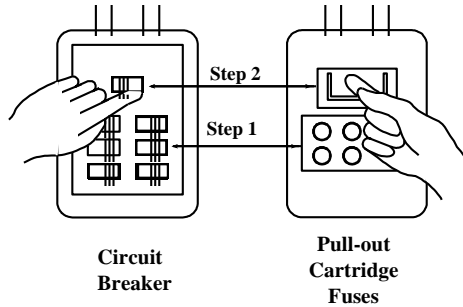

Gas Meter And Shut-Off Valve

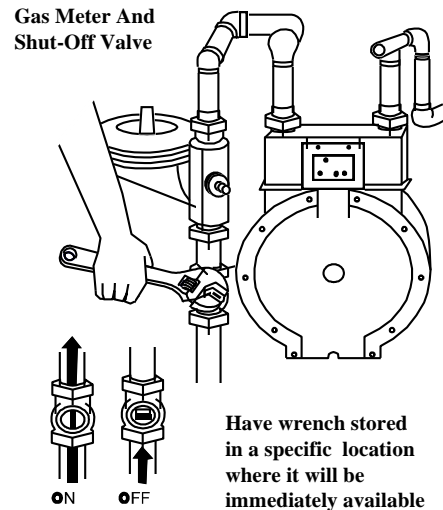

Water Shut-Off

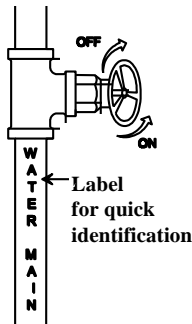

Deminta Yutiilitiyada: Koranto, Biyo, Gaas. Hannaanka deminya korantadu waxay tusaysaa labada sanduuq ee fiyuusyada iyo kan qaybshaha labo tillaabo ayuuna u tusayaa. Tallaabada 1 waa in dhamaan demiyeyaasha la demiyo (ama dhinac u rog fiyuusyada). Tallaabada 2 waa in la bakhtiiyo qaybshaha guud (ama bakhtiinta fiyuuska guud). Deminta biyuhu waxay muujinaysaa xiridda dhinac-saacad socod ee waalka si loo xiro biyaha iyo lid-saacad socod oo ah sida loo daayo. Shaxanka deminta gaas-cabbiraha wuxuu muujinayaa meesha uu ku yaallo waalka xiridda ee ka soo baxaysa dhulka. Si aad waalkaa u xirto isticmaal baanad si aad u rogto waalka dhinaca saacad wareegga afar ka meel meel wareegga ah.

**DIYAARSANAANTA GURYAHA IYO GOOBTA SHAQADA
(WELI SOCDA)**

- Dabka Guryaha: Hubi in biraha tuugada cesha iyo qfullada meesha daaqadaha bannaanka laga galo ay sahlan tahay in la furo.
- Dhulguurka/Dhiiqagguurka: Rakibo tuubbooyin debacsan oo gaas iyo biyo si aad uga digtoonaato gaas iyo biyo tifqa. Tuubbooyinka debeccan aad bay u yar tahay in ay dillaacaan.
- Dab-duureedyada:
 - Iska jir in aad jay iyo alwaxyo ka dhigatid saqaf.
 - Ka fal oo ka durji dhamaan cawska guban kara guriga ilaa 30 fiid. Ka durji geedaha gidaarrada guriga.
 - Haamaha baroobaynta dhig meel ugu yaraan 30 fiid u jirta guryaha ama dhismayaasha kale.
 - Xaabada ku dhoobo meel ugu yaraan 30 fiid u jirta guriga ur-koraadna guriga ka ah.

SAMAYSIGA QORSHE MUSIIBO

Tilmaan in qorshe musiibo ay micneheedu tahay farqiga u dhexeeya geeri iyo nolol waqtiga musiibada. Tusaale ahaan:

- Sidee uga fakan doontaa gurigaaga?
- Xaggeed kula kulmaysaa xubnaha qoyska?
- Wadiiqadeed uga bixi meesha aad deggan tahay haddii geeddi uu noqdo muhiim? Ma haysataa wadiiqo kale haddii ay tani xiran tahay ama aan si kale loo mari karaynin
- Maxaad qaadanaysaa?
- Xaggeed abbaaraysaa?
- Maxaad u baahan tahay haddaad guriga ku dhuumanaysid? Ma haysataa shay-yadaas (ama iyagoo kugu filan)?

Soo jeedi in ay ka qaybgalayaashu ciyaaraan ciyaarta “ka warran haddii” (maxaan qaban doonaa haddii ay waxaasi dhacaan?) iyadoo la soo qadayo khatar kasta oo ay bulshadu la deris tahay. Dabadeed guriga iyo meesha shaqada ka billow korna u wad si aad uga jawaabto su’aalaha sare.

**DIYAARSANAANTA GURYAHA IYO GOOBTA SHAQADA
(WELI SOCDA)**

Sharax in jawaabaha su'aalaha ay kala duwanaa karaan iyadoo ku xiran halista jirta, markaana ka qaybgalayaashu uma diyaar-garooobi karaan dhacdo kasta oo iman karta. Laakiin carrabka ku adkee, ciyaaridda "ka warran haddii" iyadoo la dulmarayo khataraha sare, in ay taasi u diyaarinayso khatar kasta oo bulshadoodan ku habsan karta

Weydii kooxda:



WEYDII SU'AAL

Imisa idinka mid ah oo diyaarsatay qorshayaal ka fakasho oo gurigaaga iyo goobta shaqada ah?

Adkee muhiimadda haysashada qorshe fakasho oo:

- Ay ka mid tahay ka baxsiga qol kasta oo guriga ka mid ah iyo aag kasta oo goobta shaqada ka mid ah.
- Tixgelinaya baahida carruurta iyo dadka jir ahaan naafada ah.



PM, PP. 1-13 &
1-14

Sharax *Tababbarrada Bixidda ee Qorshaha Guriga*. U sheeg ka qaybgalayaasha in muunad qorshe fakasho ahi ay ku jirto Buugga Ardayga. Sharax in inta badan aanay mulkiilayaasha guryuhu ku haysan gambaleelka dabka ka diga qol kasta oo guriga ka mid ah, laakiin ay muhiim tahay in gambaleelkaasi uu ku jiro heer (dabaq) kasta oo guriga ah.

Weydii ka qaybgalayaasha haddii ay qabaan su'aalo ku saabsan diyaar-garowga guriga iyo goobta shaqada.

Ku boorri ka qaybgalayaasha in ay muraajiceeyaan qorshayaashooda ka dib markii ay samaystaan. U soo jeedi in ay qabtaan tababbar qoys oo dabka ku saabsan, raacaan wadiiqooyinka fakashada ee maxalliga ah, oo ay helaan hoyga ugu dhaw si ay u xaqiijiyaan in markii ay musiibo dhacdo ay yaqaanniin waxay sameyn lahaayeen.



ABUURIDDA QORSHAHA MUSIIBADA EE QOYSKA

Meeshaad ka billaabaysid . . .

- La xiriir xafiiskaaga maaraynta gurmadyada ee maxalliga ah ama xafiiska maxalliga ah ee Laanqayrta Case e Maraykanka.
 - Ogow noocyada musiibo ee ay u badan tahay in ay ka dhacaan bulshadaada.
 - Weydii sida laguugu digi doono.
 - Ogow sida loogu diyaar-garoobo nooc kasta oo musiibo ah.
- La kulan qoyskaaga.
 - Ka wadahadla noocyada musiibo ee dhici kara.
 - Sharax sida loo diyaar-garoobo loona jawaabo.
 - Ka wadahadla waxaad samayn lahaydeen haddii geeddi laydunkula taliyo.
 - Muraajicee waxaad ka wada hadasheen.
- Qorshayso sida uu qoyskaagu u wada xiriiri lahaa haddii ay musiibadu idin kala kaxayso.
 - Dooro laba meel kulameed:
 - ✓ Meel fogaan nabdoon u jirta gurigaaga haddii uu dab dhaco.
 - ✓ Meel ka baxsan darsaashaada haddii lacalla aadba guriga ku soo noqon weydaan.
 - Dooro saaxiib gobolka-bannaanka-ka-deggan oo ah “meel kulan” oo qoyska oo dhamaa uu soo wada waco.
- Dhamaystir tallaabooyinka soo socda.
 - Telefoon kasta oo guriga yaalla ku dheji lambarrada telefoonnada gurmada.
 - Tus xubnaha masuulka ah ee qoyska sida meesha guud looga xiro biyaha, gaaska, korantada.
 - Ku rakib dawanka qiiqa heer kasta oo gurigaaga ah, gaar ahaan sariiraha agtooda; tijaabi bil kasta, batariyadana beddel sanad kasta laba jeer. (Beddel betariyada mar kasta oo aad saacadda beddeshid gu’ga iyo dayrta.)
- La xiriir waaxdaada maxalliga ah ee dab-demiska si aad wax uga baratid khatarta dabka guryaha.
 - Baro gargaarka degdegga ah iyo af-ka-af (CPR.) La xiriir xafiiskaaga maxalliga ah ee Laanqayrta Case e Maraykanka si aad uga heshid xog iyo tababar.

KOOXDA KAJAWAABIDDA XAALADDA DEGDEGGA AH EE BULSHADA
CUTUBKA 1: U DIYAARSANAANTA MUSIIBADA



PM, P. 1-14

Abuuridda Qorshaha Musiibada ee Qoyska

- La kulan derisyadaada.
 - Qorshee sida ay darisyadu u wada shaqayn karaan musiibo dabadeed. Baro oo ogow xirfadda deriskaaga (caafimaad, farsamo).
 - Balk a fikir sida aad u caawin karto deriskaaga qaba baahiyaha khaaska ah, sida waayeelka iyo dadka naafada ah.
 - Samayso qorshe daryeel carruureed ah haddii ay dhacdo in ay waalidku guriga imaan karaynin.

QORSHAYNTA FAKASHADA

Samayso qorshe fakasho oo marin lagu baxsado ka bixinaysa qol kasta. Iyadoo qayb ka ah qorshahaaga fakashada:

- Tixgeli baahida carruurta iyo shakhsiyaadka ka shakaban addimaha.
- Ku wargeli qorshaha dhamaan xubnaha qoyska ama dadka xafiiska kaala shaqeeya.
- Tababbarro muraajico oo fakashada ku saabsan samee.

Tusaale qorshe fakasho ah ayaa ka muuqda shaxanka soo socda.

Qorshe Fakasho

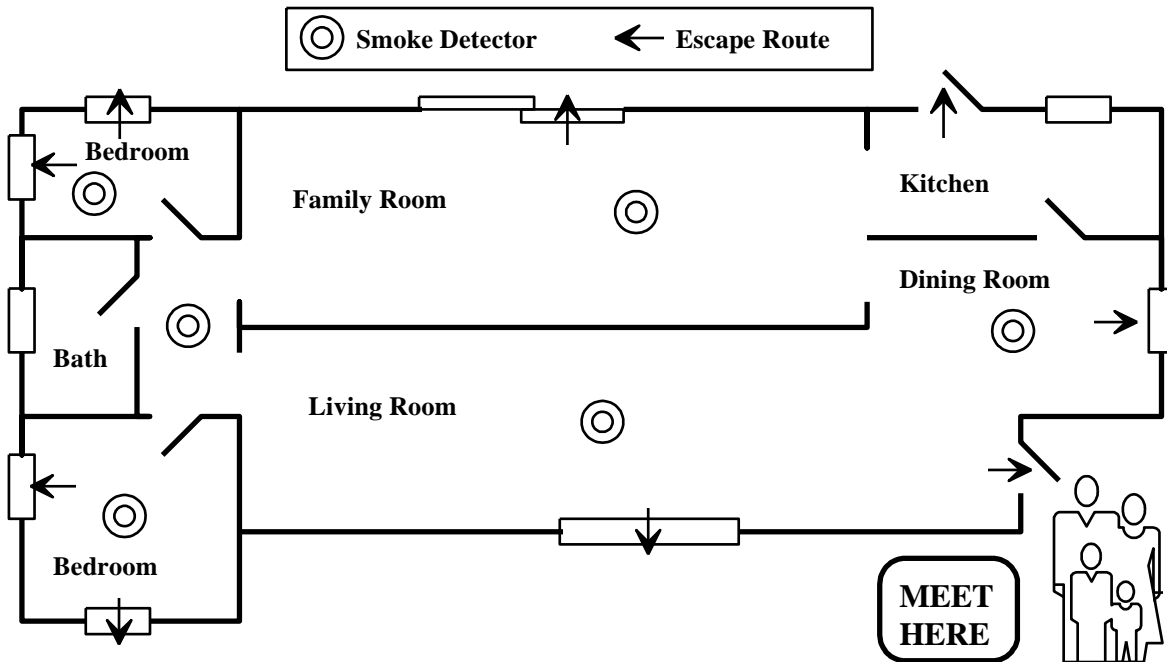

Qorshe muunad ah oo fakasho leebab leh oo muujinaya wadiiqada fakashada oo ka baxda qol kasta oo guriga ah iyo meel uu qoysku ku kulmo oo dibedda guriga ah.



PM, PP. 1-16
THROUGH 1-19



XUSUUSIN
MACALLINKA

DIYAARSANAANTA GURYAHA IYO GOOBTA SHAQADA (WELI SOCDA)

U dir ka-qaybgalayaasha *Isku-duwidda iyo Kaydinta Guntinta Sahay Musiibo* oo ku qoran Buugga Ardayga. U sheeg kooxda in layska ay ku jiraan dhamaan sahyda musiibo ee ay ku talisay FEMA.

Tilmaan in sahyda musiibo ee ku qoran layskani ay dhamaystiran tahay, soona jeedi in ay ka qaybgalayaashu go'aansadaan sahyda ay ugu baahan yihiin guuridda, kuwa ay ugu baahan yihiin guriga ku gabbashada, iyo kuwa ay labadaba ugu baahan yihiin.

- Sahayda guuridda keliya iyo sahyda (tusaale ahaan, dawada la qoray) oo loogu baahan yahay guuridda iyo gabbashada waa in lagu kaydshaa meel markiiba laga heli karo haddii ay noqoto in la guuro.
- Sahayda hoy-ku-qabbashada keliya (tusaale., 3 beri oo biyo ah qof kasta oo qoyska ka mid ah haddii uu dhaco dhulgariir ama harikeyn) waa in lagu kaydshaa meel laga gaari karo guriga ha ahaado ama goobta shaqadee.

Xulashada iyo diyarinta qof bedbaado waxaa looga hadli doonaa qaybtan mar dhaw.

KOOXDA KAJAWAABIDDA XAALADDA DEGDEGGA AH EE BULSHADA
CUTUBKA 1: U DIYAARSANAANTA MUSIIBADA



PM, P. 1-16

Isku duwidda iyo Kaydinta Guntinta Sahayda Musiibo

Waxaad la qabsan kartaa musiibada haddaad ka diyaargarowdo ka hor inta aanay kugu dhicin. Hal dariiqo ah oo lagu diyaargarooobo waa in laysku duwdo Guntin Sahay Musiibo. Markii ay musiibo ku dhufato aagga, ma heli doontid waqti aad ku dukaamaysato oo alaab ku raad-raadisid. Haddiise aad horay u aruursatay sahay, qoyskaaga iyo adiguba waxaad u babac dhigi kartaan geeddi ama guri ku gabbasho.

Si aad u Diyaarsato Guntintaada

1. Muraajicee tig-layska ku yaal dhawrka bog ee soo socota (ka yimid FEMA L-189, ARC 4463, Guntinta Sahayda Musiibo ee Qoyska).
2. Ka uruurso sahayda layska.
3. Ku rido sahayda aad u baahan doonto markii la guurayo weel aad qaadan karto. Sahaydaa waxaa ku calaamadsan xiddig (*).

Biyo

Ku kaydi biyaha weelal balaastiig ah sida caagagga cabitaannada khafiifka ah. Iska jir isticmaalidda weelalka jaba ama qoya sida kartoona caanaha iyo dhalooyinka quraaradda ah. Qof caadi u firfircoon wuxuu u baahan yahay labo kuwaarto oo biyo ah maalintii. Cimilada kulul iyo waxqabadka badan way sii laballaabaan baahidaa. Carruurta, hooyada nuujinaysa, iyo dadka jirranna in ka badan intaa bay u baahan yihiin.

- U kaydi 1 galaan oo biyo ah qofkii maalintii (2 kuwaarti oo cabitaan ah iyo 2 kuwaarti oo cunto ku diyaarin iyo nadaaafad ah.)*
- U hay ugu yaraan 3 beri sahaydood oo biyo ah qof kasta oo qoyska ka mid ah.

Haddii aad su'aalo ka qabto tayada biyaha, sifee intaadan cabbin. Waxaad kululayn kartaa biyaha ilaa heerka falfalidda hal daqiiqo, ama waxaad isticmaali kartaa kaniinnada sifeynta ee la iibsado. Waxaa kalood isticmaali kartaa kalooriinta hoorka ah haddii ay nadiif tahay oo aanay carfis lahayn, oo ay, 5.25% soodiyam haybokollorayt tahay. Si aad u sifayso biyaha, isticmaal shaxda hoos ku qoran oo ha ku hagto:

Saamiga Biyaha Lagu Nadiifiyo Kallooriinta

Cadadda Biyaha	Kallooriinta Lagu Darayo
1 kuwaarti	4 Dhibcood
1 Gaaloon	16 Dhibcood
5 Gaaloon	1 Qaaddo

Saamiga Biyaha Lagu Nadiifiyo Kallooriinta: Cadadda Biyaha iyo Kallooriinta Lagu Darayo

Ka dib markaad ku darto kallooriinta, rux oo walaaq oo u kaadi 30 daqiiqo intaadan cabbin.



PM, P. 1-17

Isku duwidda iyo Kaydinta Guntinta Sahayda Musiibo

Cunto

Kaydso ugu yaraan 3 beri sahaydood oo ah cunto aan qurmayn. Xulo cuntada an u baahnayn qaboojin, diyaarin, karin iyo biyo ama biyo yar. Hadday khasab tahay in aad cuntada kululayso, ku rido baako Sterno[®] ah. Xulo cuntada diyaarka ah oo fudud. Ku dar xulashooyin cuntooyinka hoos ku qoran ah guntintaada sahayda musiibo:

- Hilibka qasacadaysan oo cunidda u diyaarsan, miro, iyo khudaar
- Milannada qasacadaysan, caano, maraq (hadday budo yihiin biyo dheeraad ah kaydso)
- Waxyaabaha muhimka ah—sokor, cusbo, basbaas
- Cuntooyinka tamarta sare—subagga lawska, malmalaaddo, qajacle, cadad garanoola ah, iyo trayl mikis
- Cunto dhallaanka, dadka waayeelka ah, ama dadka cuntada khaaska ah qaata
- Cuntooyinka niyadda dhisa—buskud, nacinac adag, buunshe macaan, loliboby, qaxwaha budada ah, iyo caleen shaah

Alaabta Jikada

- Qasac fure gacanta ku shaqeeya
- Weelasha duurka, koobabka xaashida ah, iyo maacuun caag ah
- Mindi wax-kasta-gasha
- Kallooriinta qoyska si biyaha cabidda loogu sifeeyo
- Sokor, cusbo, basbaas
- Duubayaaasha aluuminamka ah
- Bacda xiranta
- Hadday tahay in cuntada la kariyo, burjiko yar iyo qasac shidaalka karinta ah



PM, P. 1-18

Isku duwidda iyo Kaydinta Guntinta Sahayda Musiibo

Guntinta Gargaarka Degdegga ah*

Gurigaaga iyo gaari kasta ku hayso guntin ah gargaarka degga ah. Guntin gargaarkac degdegga ah waa inuu ka kooban yahay:

- Buugga gargaarka degdegga ah
 - Faashado nadiif ah oo dhawr cayn ah
 - Cadadka faashadda oo 2-inji ah (4-6)
 - Cadadka faashadda oo 4-inji ah (4-6)
 - Sharooto lid-xasaasiyadeed (Hypoallergenic) ah
 - Faashadaha saddex xagalka ah (3)
 - Irbad
 - Tawaalado qoyan
 - Boomaato lid-bakteeriyaha ah
 - Heerkul-beeg
 - Loox-yaraha carrabka (2)
 - Dhalo batrooliyam jelli ah ama qooye kale
 - Biinanka bedbaadaha oo kala weyn
 - Nadiifiye/saabbuun
 - Galoofyada laytegis (2 joog)
 - Batrooliyam jelli
 - Cadad suufaf ah
 - Hoosiso
 - Duubab sharooto ah oo nadiif ah oo 2-inji ah (3 duub)
 - Duubab sharooto ah oo nadiif ah oo 3-inji ah (3 duub)
 - Maqas
 - Qabadeyaal
- Dawooyinka aan la Qorin**
- Aspirin ama xanuun baabbi'iyee aan aspirin ahayn
 - Dawo lid-shuban ah
 - Lid-aashito (calool kaca)
 - Sharoobbo lpecac ah (oo matagga keenta haddii ay ku taliyaan Xarunta Xakamaynta Sunta)
 - Laasatiibo (shuban keento)
 - Fiitamiinno
 - Dhuxul kacsan (oo la isticmaalo haddii ay ku taliyaan Xarunta Xakamaynta Sunta)

Qalabka iyo Sahayda

- Weelasha bannaanka, ama koobabka xaashida ah iyo maacuun caag ah*
 - Buugga diyaarsanaanta musiibada*
 - Raadiye batari ku shaqeeya iyo batari dheeraad ah*
 - Toosh iyo batariyo dheeraad ah*
 - Dab-demiye: qasac yar, nooca ABC
 - Tuubbo teendho
 - Biinseyaal
 - Sharootada dhakt
 - Jiheeye
 - Tarraq ku jira weel biyaha ka adag
 - Jeexyo Aluuminam ah
 - Weelal kaydineed oo bac ah
 - Baaqeyaal (sha) shidma
 - Xaashi, qalin rasaas
 - Irbado, dun
 - Galoofyada shaqada
 - Dawo ride
 - Baanadda xiridda oo lagu xiro gaaska iyo biyaha qoyska
 - Firimbi
 - Gogol bac ah
- Nadaafad**
- Xaashida musqusha, shukumaanno*
 - Saabbuun, nadiifiye hoor ah*
 - Sahayda haweenka*
 - Alaabta nadaafadda shaqsiga*
 - Jawaanka qashinka oo caag ah, xargo (oo nadaafadda shaqsi loo isticmaalo)
 - Baaldi caag ah oo dabool dhuuqsan leh
 - Caabuq-dile
 - Kallooriinta guriga



PM, P. 1-19

Isku duwidda iyo Kaydinta Guntinta Sahayda Musiibo

Dharka iyo Gogosha

Ku dar dharka ugu yaraan hal joog oo dhar beddelasho iyo kabo ah qofkiiba.

- Kabo adag ama buudka shaqada*
- Qalab roob*
- Busteyaal iyo qandiga jiifsiga*
- Koofi iyo galoofyo*
- Kastuumooyin kulul*
- Ookiyaalaha cadceedda*

Dikumiintiga Guriga iyo Lambarrada Xiriirka

- Aqoonsiga qofka, lacag (sarrif ku jiro) ama jeegga masaafurka iyo kaarka deynsiga
- Nuqullada xaashiyasha muhiimka ah: shahaadooyinka dhalashada, kuwa guurka, shatiga darawalnimada, kaararka sooshalka, baasaboorrada, qormooyinka wakiilashada, dardaaranada qoran, diiwaanka alaabta guriga, xaashiyaha caymiska, lambarrada bangiga iyo karaka deynta, istoogyada iyo curaaraha. Hubi in aad alaabtaa ku xaraysid wel biyo-makaraan ah
- Lambarrada telefoonnada iyo layska xiriirrada gurmada
- Khariidadda aagga iyo lambarka meelaha aad aadi kartid
- Furayaal gaariga iyo guriga oo dheeraad ah

Walxaha Gaarka ah

Xusuuso xubnaha qoyska oo baahida khaaska ah qaba, sida dhallaanka ama dadka naafada ah ama waayeelka ah.

Cunugga*

- Foormala
- Xafaayado
- Dhalooyin
- Caano boore
- Dawooyin

Dadka waaaweyn*

- Dawada wadnaha iyo dhiig karka
- Insulin
- Dawooyinka loo qoray
- Baahida ilkaha macmalan
- Indha-galaha iyo sahaydiisa
- Okkiyaale dheeraad ah oo aragga

- Madaddaalo—cayaaraha iyo buugta
- Xaashiyaha qoyska ee muhiimka ah —kuwaan ku xaree weel la qaadan karo oo aanay biyuhu karin.
- Dardaaranka, boolasiga caymiska, heshiisyada, qormooyinka, istoogyada iyo curaarrada
- Baasaboorrada, sooshalka, diiwaanka tallaallada
- Lambarrada akoonka bangiga
- Lambarrada akoonnada iyo shirkadaha kaararka deynta
- Diiwaanka alaabta muhiimka ah ee guriga
- Lambarrada telefoonnada ee muhiimka ah

*walxaha ay xiddigtu ku calaamadaysan tahay waxaa loo doorbidaa geeddiga.

**DIYAARSANAANTA GURYAHA IYO GOOBTA SHAQADA
(WELI SOCDA)**

GUURID MISE GURI-KU-GABBASHO?

Tilmaan in go'aanka geeddiga ama meesha ku gabbashadu aanu ahayn mid sahlan mar kasta. Haddii ay meesha iyo waqtigu oggolaadaan waa in ay ka dhegaystaan Habka Digniinta Gurmada (Emergency Alert System EAS) tilmaamo ay bixiyaan xirfadlayaasha maareynta ee xaaladda qiimaynaya.



XUSUUSIN
MACALLINKA

Xusuuso: Ka muraajicee halista aagga hannaannada guuridda iyo meel-ku-gabbashada. Geli cinwaanno qoran si aad ugu taageerto soo jeedintaada bandhigga ah.

DIYAARSANAANTA BULSHADA

Soo bandhig diyaarsanaanta bulshada adigoo sharxaya in diyaarsanaanta muwaaddinka aanay wax badan tareyn hadii aanay bulshadu diyaarsanayn. Wakiillada hay'adka doorarka ku leh jawaabaha waa in ay wada shaqeeyaan si ay u wada abaabulaan hawlaha hay'adahooda inta aanu gurmada ama musiibadu dhicin. Maxsuulka wada-shaqayntaas ayaa la yiraahdaa Qorshaha Hawlaha Gurmada (Emergency Operations Plan, ama EOP.

QORSHAHA HAWLAHA GURMADA (EOP)**BANDHIG
MUUQAAL****EOP-da**

- Wuxuu masuuliyado kala siiyaa ururrada iyo shakhsiyaadka
- Kala saaraa awoodaha iyo madaxdooda
- Qeexaa sida dadka iyo hantida loo bedbaadinayo
- Aqoonsadaa shaqaalaha, qalabka, tas-hiilaadyada, sahayda, iyo khayraadka kale

Sharax in EOP ay yihiin xaashiyo:

- Masuuliyado kala siiyaa ururrada iyo shaqsiyaadka si ay u qabtaan shaqooyin cayiman waqti go'an iyo meelo go'an oo markaa ka badan awoodda waxqabasho ee hal hay'ad oo kasta (tusale, waaxda dabdemiska).
- Kala saaraa awoodaha iyo xiriirka ururrada, wuxuuna muujiyaa sida loo agaasimayo waxqabadyada.
- Qeexaa sida dadka iyo hantida loo bedbaadinayo inta lagu jiro gurmadyada iyo musiibooyinka.
- Aqoonsadaa shaqaalaha, qalabka, tas-hiilaadyada, sahayda, iyo khayraadka kale ee la heli karo—oo aag sharciyeedkaa yaalla ama lagula heshiiyey aag kale—in waxqabadkan loo isticmaalo inta lagu jiro hawlaha waxqabadka iyo ka kabashada.

Iyadoo kooban, EOP waxay qeexdaa sida ay bulshadu hawl u qabsanayso markii ay musiibo dhacdo.



**BANDHIG
MUUQAAL**

DIYAARSANAANTA BULSHADA (WELI SOCDA)

DIYAARSANAANTA BULSHADA IYO CERTYADA

CERTyada Meeshay Musiibo ka Jirto

- Waxay cawiyaan jawaabayaasha degdegga ah markii laga codsado
- Marka hore waxay qabtaan hawsha muhimka ah ee shaqaalaha waxqabashada inta uu gurmada ka imanayo:
 - Ka nabadgelidda dabka
 - Goobid iyo samatabbixin khafiif ah
 - Hawlaha caafimaad ee musiibada

Tilmaan in bulshooyinku ay u diyaargaroobaan musiibo markii samaystaan Kooxaha KaJawaabidda Xaaladda Degdegga ah ee Bulshada (Community Emergency Response Teams CERTs) si ay uga jawaabaan waqtiga ay markaasi musiibadu dhacday oo markaa xirfadlayaashii arrintaa ay hawshu ka badato ama ay daahaan. Sharax in CERTyadu ay:

- Caawiyaan jawaabayaasha degdegga ah markii laga codsado iyadoo la eegayo habraaca hawsha ee lagu shaqaynayo ee ay dejisay hay'adda hawsha wadda
- Qabtaan in badan oo ka mid ah hawlihii xirfadlayaasha gargaarka degdega ah musiibo dabadeed marka ay xirfadlayaashii arrintaa ay hawshu ka badato ama ay daahaan.
 - Ka nabadgelidda dabka
 - Goobid iyo samatabbixin khafiif ah
 - Hawlaha caafimaad ee musiibada



PM, P. 1-23

DIYAARSANAANTA BULSHADA (WELI SOCDA)

DIYAARSANAANTA BULSHADA IYO CERTYADA

U dir ka qaybgalayaasha shaxda cinwaankeedu yahay, *Abaabulnaanta/Ururka CERT (CERT Organization)* oo ku jira Buugga Ardayda. Tilmaan in xisadaha dambe, ay ku baran doonaan in badan oo ka mid ah hawlaha iyo aagagga CERT.

Adkee in wax kasta oo ay tahay hawsha xubnaha CERT loo xilsaaray, in CERTyada waxgalka uhu ay u baahan yihiin wadashaqayn.

U sheeg kooxda in uu jiro tig-lays ku jira qaybta *Alaabo Dheeraad ah* oo dhabarka Cutub 1 ee Buugga Ardayda ku yaalla, oo ka caawin doona qorshaynta iyo abaabulidda CERT iyo isu geynta qalabka iyo sahayda kox CERT ay u baahan tahay.

Weydii ka qaybgalayaasha in ay qabaan wax su'aalo ah oo ku saabsan diyaarsanaanta bulshada.

KOOXDA KAJAWAABIDDA XAALADDA DEGDEGGA AH EE BULSHADA
CUTUBKA 1: U DIYAARSANAANTA MUSIIBADA



PM, P. 1-23

Abaabulnaanta CERT

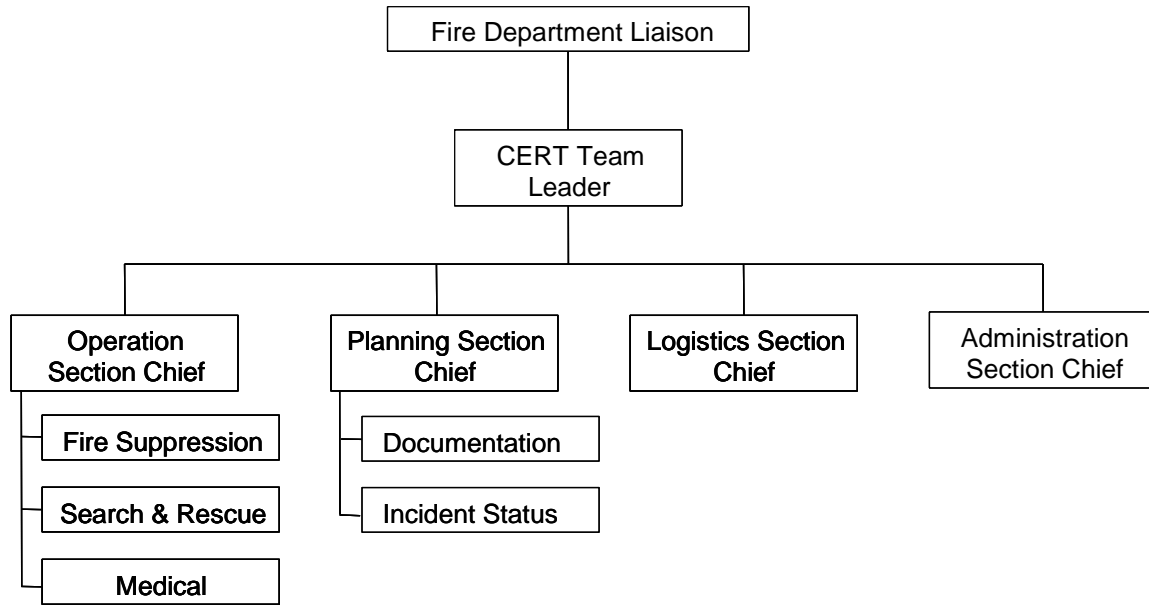

Ururka CERT oo tusaya waxa ugu sarreeya Wakiilka Waaxda Dabdemiska. Waxaa ka hooseeya Hoggaamiyaha Kooxda CERT oo agaasima hawlaha afarta qaybood: Hawlgallada, qorshaynta, Sahayda, iyo Maamulka. Tan ka hoosaysa Qaynta Hawlgallada waa saddex koox jawabeed: Dab Xakamaynta, Goobid Samatabbixinta, iyo Dawada. Hoosta Waaxda Qorshaynta waxa ku yaal laba qaybood: Xaashiyayn, iyo Marxaladda Dhacdada.



PM, P. 1-24

ILAALINTA SHAQAALAHA MUSIIBADA

Sharax in, xubnaha CERT ee ka shaqaynaya adeegyada gurmadyada waxaa si guud u ilaaliya sharciyada “Good Samaritan” oo iyagu dhawra dadka u bixiya daryeelka gurmadka si taxaddar iyo macquulnimo leh.

Tilmaan in inta gurmadka lagu jiro, xubnaha CERT ay sidaa oo kale ilaaliyaan Volunteer Protection Act ee 1997, oo ah sharci Federaali ah oo dhawra mutaddawiciinta inta ay ku hawlgalayaan tababbarradii ay hore u qaateen.

U sheeg ka qaybgalayaasha in ay jirto shax la yiraahdo *Sharciyada la Dabbakhi karo iyo Qodobbada Muhiimka ah* oo ku qoran Buugga Ardayda, oo ay tahay in ay ku dul qoraan sharciyada la dabbakhi karo iyo qodobbada muhimka ah ee Gobolkooda.

Sharax ilaalinta gaarka ah ee ay bixiyaan sharciyadu tilmaanna qaamaysnaanta ka baxsan ilaalinta sharciyadaa.

KOOXDA KAJAWAABIDDA XAALADDA DEGDEGGA AH EE BULSHADA
CUTUBKA 1: U DIYAARSANAANTA MUSIIBADA



PM, P. 1-24

Sharciyada la Dabbakhi Karo iyo Qodobbada Muhiimka ah

Sharciyada la Dabbakhi Karo	Qodobbada Muhiimka ah



**BANDHIG
MUUQAAL**



**GEBAGGABEE
CUTUBKA**

GABAGGABADA CUTUBKA

Gabaggabada Cutubka

- CERTyada waxay ka mid yihiin hay'ado iyo shaqaale kala duwan oo wada shaqeeya si ay caawin u bixiyaan gurmada ka gadaal
- CERTyada waxay ku caan baxeen in ay muhim u yihiin meelaha lagu tijaabiyey. Bulshadanna waxay u noqon karaan kuwo aan laga maarmin..
- CERTyada waxay noqdeen qayb muhiim ah oo ka mid ah Citizen Corps-yada.

Soo koob cutubka adigoo qodobbada soo socda soo qaadaya:

- CERTyada waxay ka mid yihiin hay'ado iyo shaqaale kala duwan oo wada shaqeeya si ay caawin u bixiyaan gurmada ka gadaal. Waxyaabaha furaha u noqday guusha CERT waxay ku jiraan:
 - Aqoon u lahaanta noocyada haliseed ee khatarta weyn ku haya aagga iyo burbyrrada ay keeni karaan dhacdooyinka.
 - Diyaarsanaan ku filan dhacdo kasta iyo gadaasheeda
 - Tababar meelaha hawlaha ee loo xilsaaray CERTyada.
 - Muraajicayn jilid iyo ku celcelin ah.
- CERTyada waxay ku caan baxeen in ay muhim u yihiin meelaha lagu tijaabiyey. Bulshadanna waxay u noqon karaan kuwo aan laga maarmin.
- CERTyada waxay noqdeen qayb muhiim ah oo ka mid ah Madaxweyne Bush Citizen Corps-yadiisii.

Weydii ka qaybgalayaasha haddii ay qabaan wax su'aalo ah oo ku saabsan waxyaabihii looga hadlay cutubkan.

GABAGGABADA CUTUBKA (WELI SOCOTA)

XILSAAR SHAQO-GURI

U sheeg ka qaybgalayaasha in cutubka xiga uu ka hadli doono nabdoonaanta dabka. Casharka kan xiga ka hor waa in ay:

1. Aqriyaan oo fahamaan Cutubka 2: Nabdoonaanta Dabka ee Buugga Ardayga.
2. Keenaan galoofyo magad ama saan ah iyo muraayadaha bedbaadsanaanta si ay ugu isticmaalaan dab xakamaynta, ayna u noqdaan billowgii guntintooda sahayda musiibada.
3. Billaabaan kaydsiga cunto iyo biyo oo ku filan iyaga iyo qoysaskooda ugu yaraan 3 beri.
4. Samaystaan xiriir gobolka-ka-baxsan.
5. Ogaadaan meelaha gurigooda ka mid ah ee laga xiri karo yutiilitiga.

U sheeg kooxda in ay soo xirtaan dhar ku habboon casharka soo socda (Dabaggaab iyo kabo furan toona maya), waayo waxay baran doonaan sida dab yar loogu demiyo dab damiye yar.

Ka qaybgalayaasha uga mahadceli ka soo qaybgelidda xisaddan.